

IT

**Essentials I:
PC Hardware
and Software**



The Central Processing Unit (CPU)

IT Essentials Chapter 1

Microprocessor History

- When the Hungarian born John von Neumann, first suggested storing a sequence of instructions (a program) in the same memory as the data.
- That was in his "First Draft of a Report on the EDVAC", written in 1945. The report organized the computer system into four main parts: the Central Arithmetical unit, the Central Control unit, the Memory, and the Input/Output devices.
- Today, more than half a century later, nearly all processors have a "von Neumann" architecture.

Microprocessor History

- A microprocessor -- also known as a **CPU** or central processing unit -- is a complete computation engine that is fabricated on a single chip. The first microprocessor was the Intel 4004, introduced in 1971. The 4004 was not very powerful -- all it could do was add and subtract, and it could only do that 4 bits at a time. But it was amazing that everything was on one chip. Prior to the 4004, engineers built computers either from collections of chips or from discrete components (transistors wired one at a time). The 4004 powered one of the first portable electronic calculators.

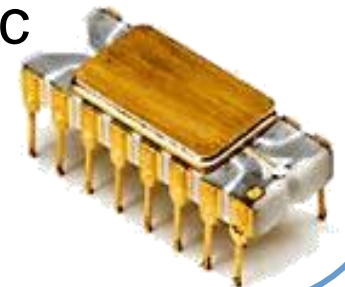

Microprocessor History

- The first microprocessor to make it into a home computer was the Intel 8080, a complete 8-bit computer on one chip, introduced in 1974.
- The first microprocessor to make a real splash in the market was the Intel 8088, introduced in 1979 and incorporated into the IBM PC (which first appeared around 1981).
- The PC market moved from the 8088 to the 80286 to the 80386 to the 80486 to the Pentium to the Pentium II to the Pentium III to the Pentium 4 to Dual/Quad/Six/Eight Cores. All of these microprocessors are made by Intel and all of them are improvements on the basic design of the 8088.

Attributes Used to Rate CPU

- CPU speed measured in Hertz, Megahertz or Gigahertz
- Efficiency of programming code
- Number of transistors
- Number of registers
- Data path
- Maximum number of memory addresses
- Amount of memory included with the CPU
- Multiprocessing ability
- Special functionality

How the CPU Works

- Input/output (I/O) unit
 - Manages data and instructions entering and leaving the CPU
- Arithmetic logic units (ALUs)
 - Do all comparisons and calculations
- Control unit
 - Manages all activities inside the CPU itself
- Memory unit
 - Everything the CPU access must first be stored in memory

How the CPU Works

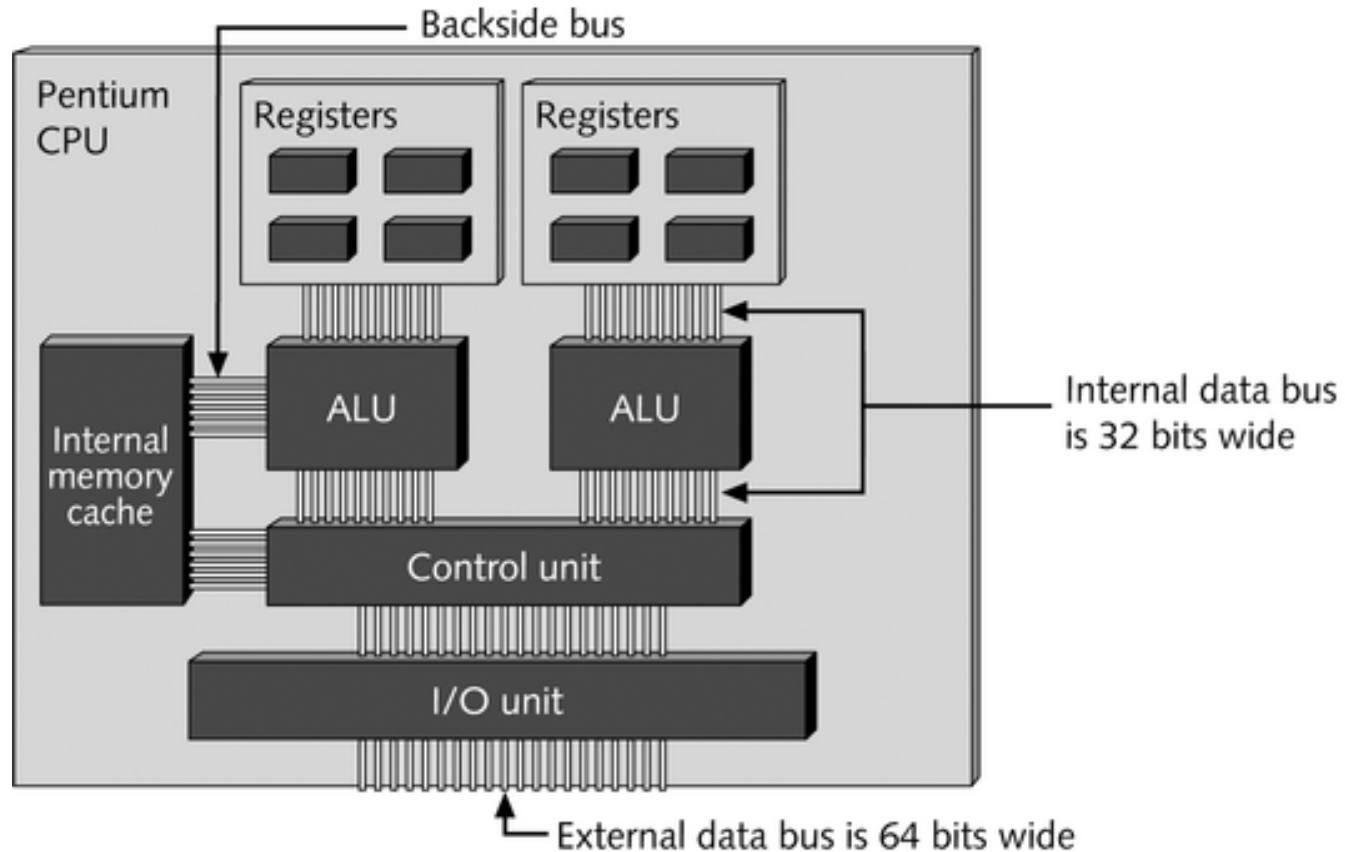

Beginning with the Pentium, CPUs had two arithmetic logic units and could process two instructions at once.

CPU Packages

- SECC (Single Edge Contact Cartridge)
- SEP (Single Edge Processor)
- PPGA (Plastic Pin Grid Array)
- PGA (Pin Grid Array)
- LGA (Land Grid Array)
- SPGA (Staggered Pin Grid Array)
- mPGA (Micro Pin Grid Array)

Pin Grid Array and Land Grid Array

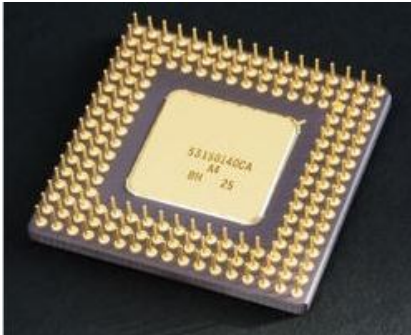

- The Pin Grid Array is the most common type of CPU. It is inserted into a **Zero Insertion Force (ZIF)** socket mounted on the motherboard.

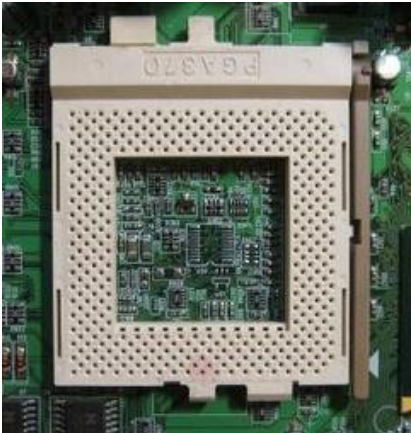

- You will hear this type of processor referred to as a ZIF Chip.
- Our newest CPUs are using the LGA socket.



- [Comparison](#)

CPU Slots and Sockets

- The physical connection used to connect the CPU to the system board
- Terminology like socket 7, socket 370, socket 423, or Slot1, will frequently be encountered.
- Socket **X** (X being any numerical number) is a descriptive term for the way certain processors plug into a computer motherboard so that it makes contact with the motherboard's built-in circuitry or data bus.
- Slot-type processors had a very brief lifespan (just about a year in the market).
 - Slots 1 and 2 are proprietary Intel slots
 - The Pentium II primarily used slot 1
 - Slot A is a proprietary AMD slot (Athlon)

CPU Slots and Sockets

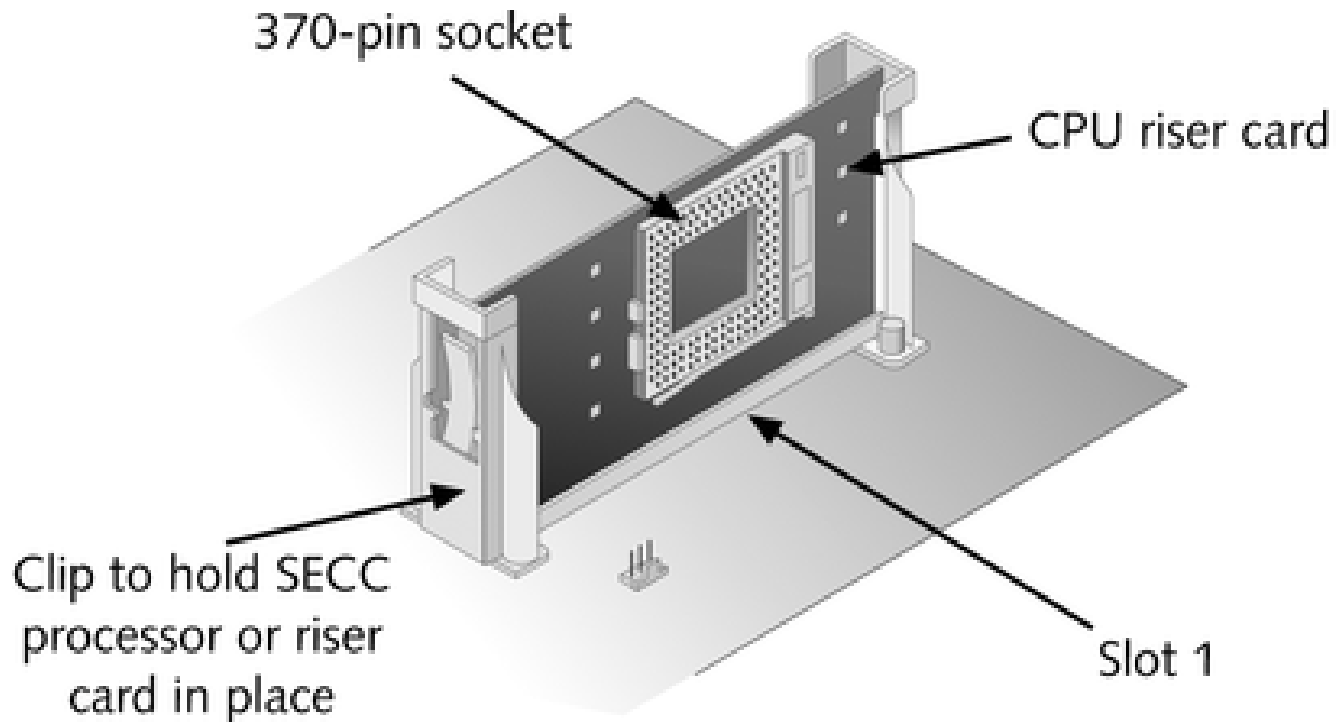

A riser card can be used to install a socket type processor into a motherboard with a slot style.

Cache

- One method of increasing the memory-access speed of a computer is called caching. This memory management method assumes that most memory accesses are made within a limited block of addresses. Therefore, if the contents of these addresses are relocated into a special section of high-speed SRAM, then the microprocessor could access these locations without requiring any wait states.

Cache

- Take the processor's bus speed and L1, L2, and L3 caches into account as well as the clock speed.
- The instruction bus determines how quickly instructions get from RAM to the processor; if a processor has a slower bus, processing time might be wasted waiting for the next instruction to arrive.
- The L1 and L2 caches store frequently used instructions so that the computer can get them faster than it could fetch them from RAM.
- The L1 cache is faster than the L2 cache.

Microprocessor Performance

- More transistors also allow for a technology called **pipelining**. In a pipelined architecture, instruction execution overlaps. So even though it might take five clock cycles to execute each instruction, there can be five instructions in various stages of execution simultaneously. That way it looks like one instruction completes every clock cycle.
- Many modern processors have multiple instruction decoders, each with its own pipeline. This allows for multiple instruction streams, which means that more than one instruction can complete during each clock cycle. This technique can be quite complex to implement, so it takes lots of transistors.

Multiprocessing

- Multiprocessing is running a system with more than one processor. The theory is of course that you can double performance by using two processors instead of one. And the reality of course is that it doesn't work this well, although multiprocessing can result in improved performance under certain conditions. In order to employ multiprocessing effectively, the computer system must have all of the following in place:
- **Operating System Support:** An operating system that supports multiprocessing, such as Windows XP or Windows Vista/7.

Multiprocessing

- Multiprocessing can be said to be either *asymmetric* or *symmetric*. The term refers to how the operating system divides tasks between the processors in the system.
- Asymmetric multiprocessing designates some processors to perform system tasks only, and others to run applications only. This is a rigid design that results in lost performance during those times when the computer needs to run many system tasks and no user tasks, or vice versa.
- Symmetric multiprocessing, often abbreviated *SMP*, allows either system or user tasks to run on any processor, which is more flexible and therefore leads to better performance. SMP is what most multiprocessing PC motherboards use.

MMX

- MMX is a set of multimedia instructions built into Intel processors. MMX enabled microprocessors can handle many common multimedia operations that are normally handled by a separate sound or video card. However, only software especially written to call MMX instructions can take advantage of the MMX instruction set.

Hyper-threading

- Some CPUs incorporate hyper-threading to enhance the performance of the CPU.
- The process of scheduling multiple processes simultaneously among multiple logical processors
- To an operating system, a single CPU with hyper-threading appears to be two CPUs.

The Pentium and Its Competitors

- Pentium processor is a true multiprocessor (has two ALUs)
- Terminology
 - Bus speed
 - Processor speed
 - The multiplier
 - Memory cache

Microprocessor Progression

- **Microns** is the width, in microns, of the smallest wire on the chip. For comparison, a human hair is 100 microns thick. As the feature size on the chip goes down, the number of transistors rises.
- **Data Width** is the width of the ALU. An 8-bit ALU can add/subtract/multiply/etc. two 8-bit numbers, while a 32-bit ALU can manipulate 32-bit numbers. An 8-bit ALU would have to execute four instructions to add two 32-bit numbers, while a 32-bit ALU can do it in one instruction. In many cases, the external data bus is the same width as the ALU, but not always. The 8088 had a 16-bit ALU and an 8-bit bus, while the modern Pentiums fetch data 64 bits at a time for their 32-bit ALUs.
- **MIPS** stands for "millions of instructions per second" and is a rough measure of the performance of a CPU. Modern CPUs can do so many different things that MIPS ratings lose a lot of their meaning, but you can get a general sense of the relative power of the CPUs from this column.

Microprocessor Progression: Intel

Name	Date	Transistors	Microns	Clock speed	Data width	MIPS
4004	1971	2,300	10	740 KHz	4 bits	.07
8080	1974	6,000	6	2 MHz	8 bits	0.64
8088	1979	29,000	3	5 MHz	16 bits	0.33
80286	1982	134,000	1.5	6 MHz	16 bits	1
80386	1985	275,000	1.5	16 MHz	32 bits	5
80486	1989	1,200,000	1	25 MHz	32 bits	20
Pentium	1993	3,100,000	0.8	60 MHz	32 bits 64-bit bus	100
Pentium II	1997	7,500,000	0.35	233 MHz	32 bits 64-bit bus	~300
Pentium III (370)	1999	9,500,000	0.25	450 MHz	32 bits 64-bit bus	~510
Pentium 4 (LGA775)	2000	42,000,000	0.18	1.5 GHz	32 bits 64-bit bus	~1,700
Core 2 Duo (LGA775)	2006	291,000,000	0.065	3.0 GHz	32 bits 64-bit bus	~7,000
i3, i5, i7 (LGA1155)	2009					

Complete list

CISC(complex instruction set computer)

- CISC is the traditional architecture of a computer, in which the CPU uses microcode to execute very comprehensive instruction set. These may be variable in length and use all addressing modes, requiring complex circuitry to decode them.
- For a number of years, the tendency among computer manufacturers was to build increasingly complex CPUs that had ever-larger sets of instructions. In 1974, John Cocke of IBM Research decided to try an approach that dramatically reduced the number of instructions a chip performed. By the mid-1980s this had led to a number of computer manufacturers reversing the trend by building CPUs capable of executing only a very limited set of instructions.

RISC (reduced instruction set computer)

- RISC CPUs keep instruction size constant, ban the indirect addressing mode and retain only those instructions that can be overlapped and made to execute in one machine cycle or less.
- One advantage of RISC CPUs is that they can execute their instructions very fast because the small set of instructions.
- Another, perhaps more important advantage, is that RISC chips require fewer transistors, which makes them cheaper to design and produce.

64-bit Processors

- Sixty-four-bit processors have been with us since 1992, and in the 21st century they have started to become mainstream. Both Intel and AMD have introduced 64-bit chips, and the Mac G5 sports a 64-bit processor. Sixty-four-bit processors have 64-bit ALUs, 64-bit registers, 64-bit buses and so on.



64-bit Processors

- One reason why the world needs 64-bit processors is because of their **enlarged address spaces**. Thirty-two-bit chips are often constrained to a maximum of 2 GB or 4 GB of RAM access. However, a 4-GB limit can be a severe problem for server machines and machines running large databases. And even home machines will start bumping up against the 2 GB or 4 GB limit pretty soon if current trends continue.
- A 64-bit chip has none of these constraints because a 64-bit RAM address space is essentially infinite for the foreseeable future -- 2^{64} bytes of RAM is something on the order of a quadrillion gigabytes of RAM (1,000,000,000,000,000 Gb or 1,024 terabytes or 1 petabyte).
- With a 64-bit address bus and wide, high-speed data buses on the motherboard, 64-bit machines also offer faster I/O (input/output) speeds to things like hard disk drives and video cards. These features can greatly increase system performance.

Intel Itaniums

- Used a Pin Grid Array
- Intel's first 64-bit processor for microcomputers
- Designed for high-end enterprise servers
- Uses a new instruction set called the EPIC (explicitly parallel instruction computing) architecture
- AMD Opteron and Turion

Xeon

- Intel's Server CPU
- x86 and 64x versions
- Have more cache than their desktop counterparts
- Multiprocessing capabilities
- Xeon processors have been in the top ten of the fastest supercomputers in the world



Sun SPARC Processor

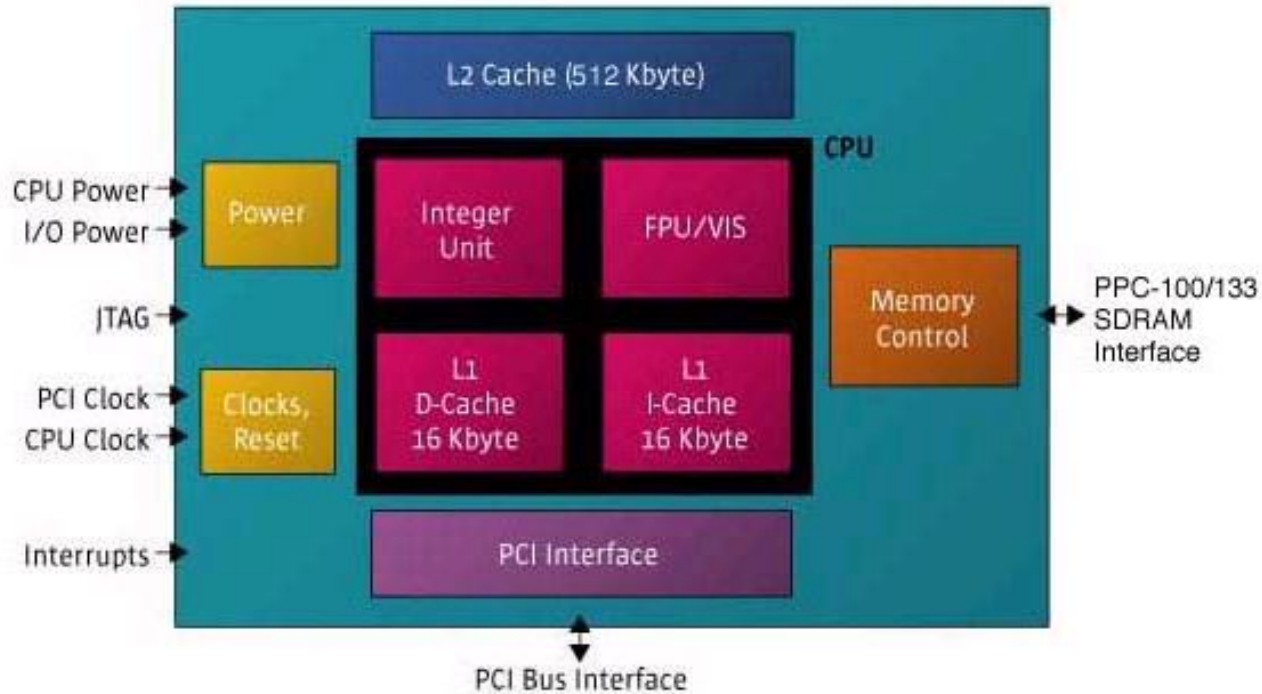

The SPARC processor is a 64-bit processor built to run Sun Unix servers.

Eliminated the Northbridge by incorporating the memory and PCI controllers into the CPU.

Multi-Core Processors

- The latest processor technology has resulted in CPU manufacturers finding ways to incorporate more than one CPU core onto a single chip. Many CPUs are capable of processing multiple instructions concurrently:
 - **Single Core CPU** – One core inside a single CPU chip that handles all of the processing capability. A motherboard manufacturer may provide sockets for more than one single processor, providing the ability to build a powerful, multi-processor computer.
 - **Dual Core CPU** – Two cores inside a single CPU chip in which both cores can process information at the same time.
 - **Quad Core CPU** – Four cores inside a single CPU chip.
 - **Six/Eight Core CPU** – Six/eight cores inside a single CPU chip.

Thermal Compound

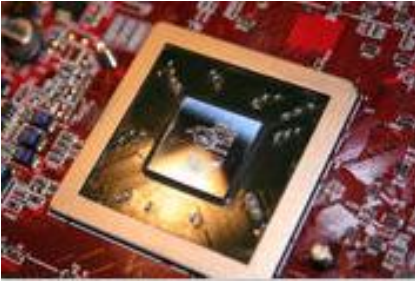

- Thermal compound is necessary to create a reliable transfer of heat from your computer's processor to its heatsink to keep your CPU from overheating.
- A unique high-density filling of micronized silver and enhanced thermally conductive ceramic particles provides superior level of performance and stability. Arctic Silver 5 is optimized for use between modern high-power CPUs and high performance heatsinks or water-cooling solutions.



CPU Heat Sinks and Cooling Fans

- Heat sinks
 - Used by older CPUs to pull heat away from the CPU
 - Clip-on devices that mount on top of the CPU
- Cooling fans
 - Keep temperatures below the Intel maximum limit of 185 degrees F/85 degrees C

Microprocessor Cooling Systems

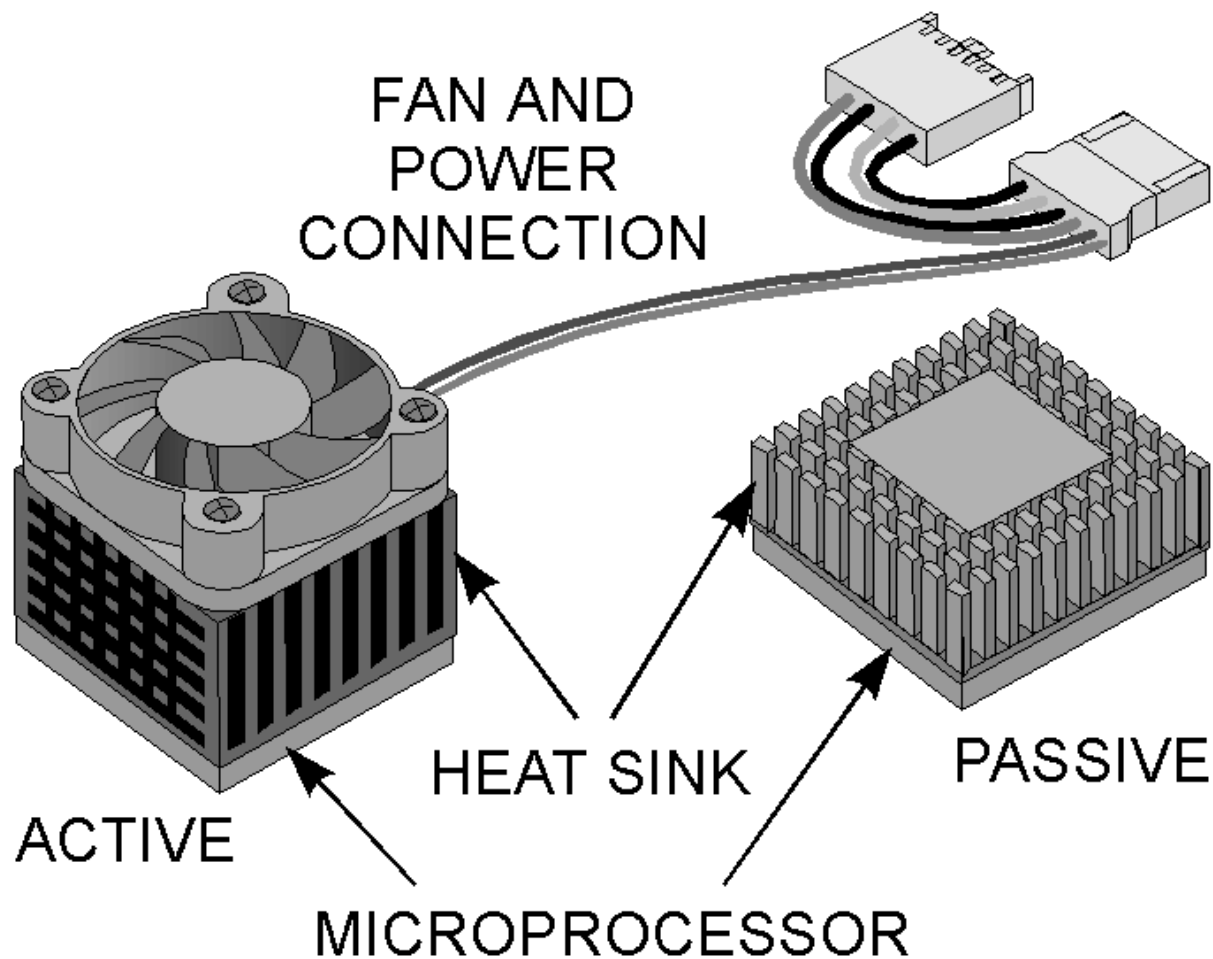

CPU Cooling Fan

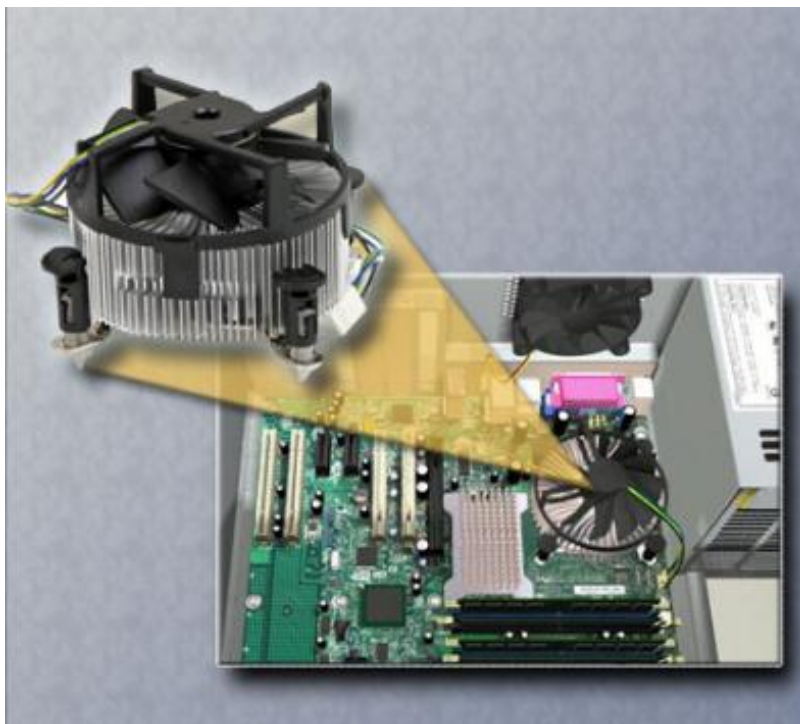

- Electronic components generate heat. Heat is caused by the flow of current within the components. Computer components perform better when kept cool. If the heat is not removed, the computer may run slower. If too much heat builds up, computer components can be damaged.

CPU Cooling Fan

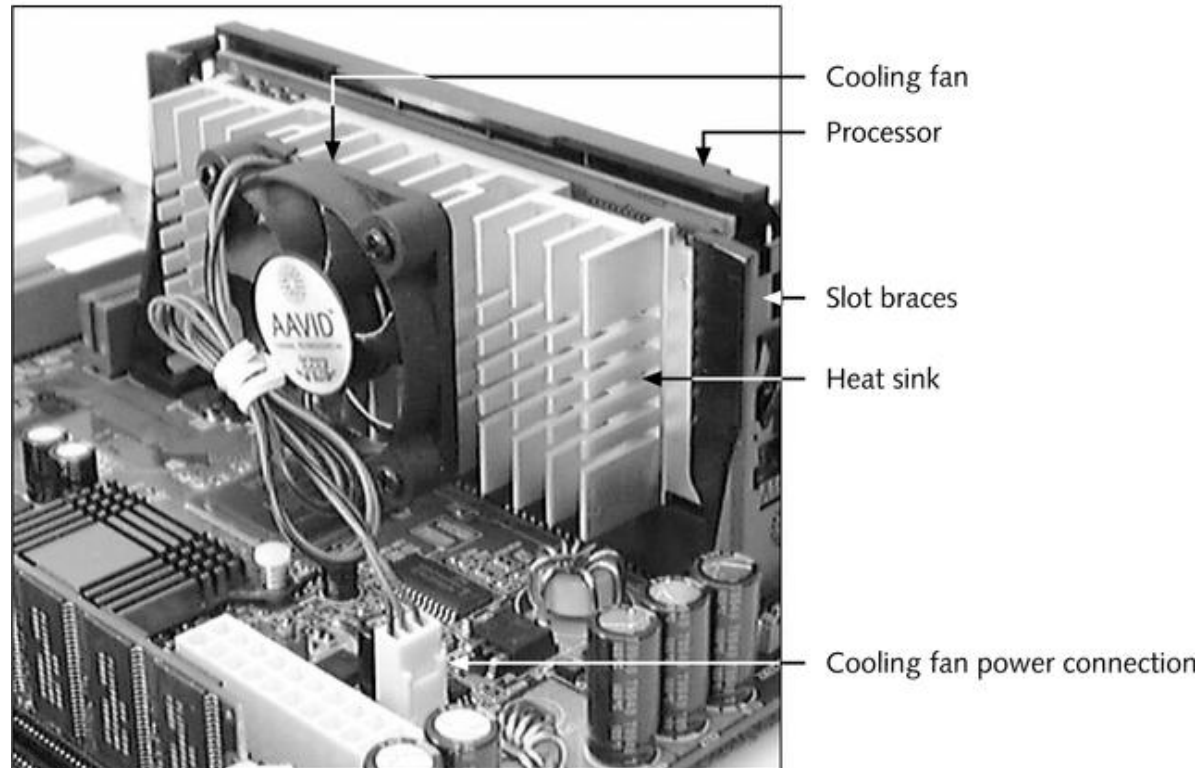

A CPU cooling fan mounts on the top or side of the CPU housing and is powered by an electrical connection to the motherboard.

More Cooling

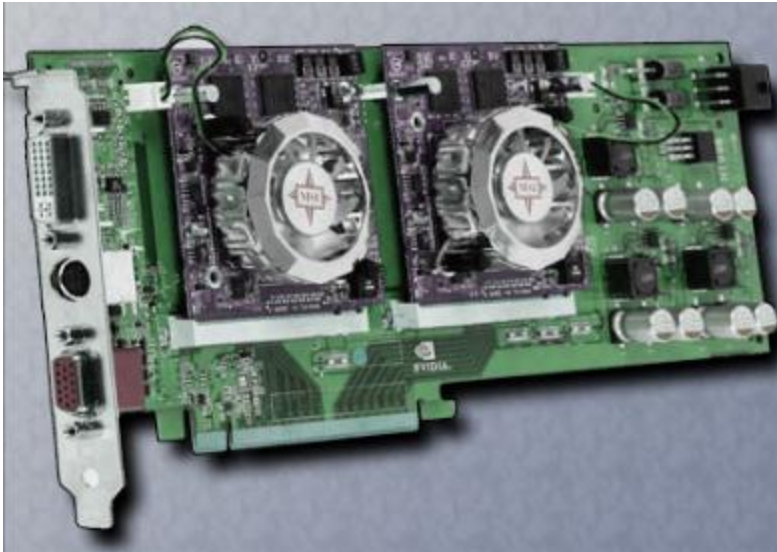

- Other components are also susceptible to heat damage and are sometimes equipped with fans. Video adapter cards also produce a great deal of heat. Fans are dedicated to cool the graphics-processing unit (GPU).

Water Cooling

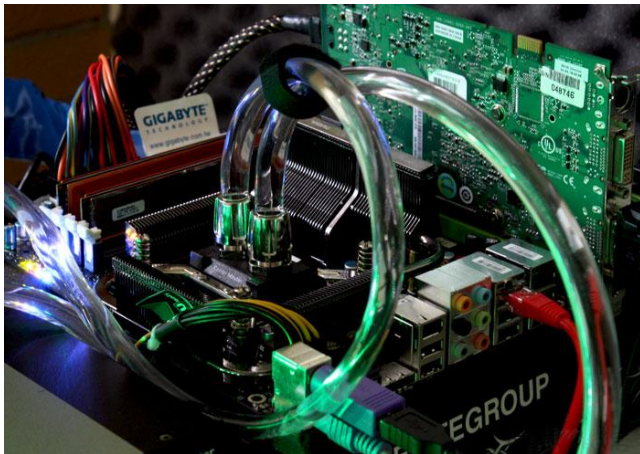

- Computers with extremely fast CPUs and GPUs may use a water-cooling system.
- A metal plate is placed over the processor and water is pumped over the top to collect the heat that the CPU creates. The water is pumped to a radiator to be cooled by the air, and then re-circulated.

CPUs

A+ Essentials Review



The fastest cache in a computer is:

- ✓ 1. L1
2. L2
3. L3
4. L4

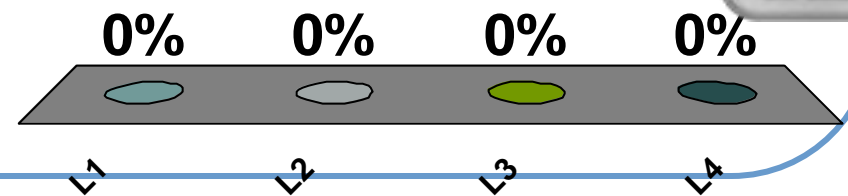

Which of the following processors uses a pin array cartridge?

1. Athlon XP
- ✓ 2. Itanium
3. Xeon
4. Pentium 4

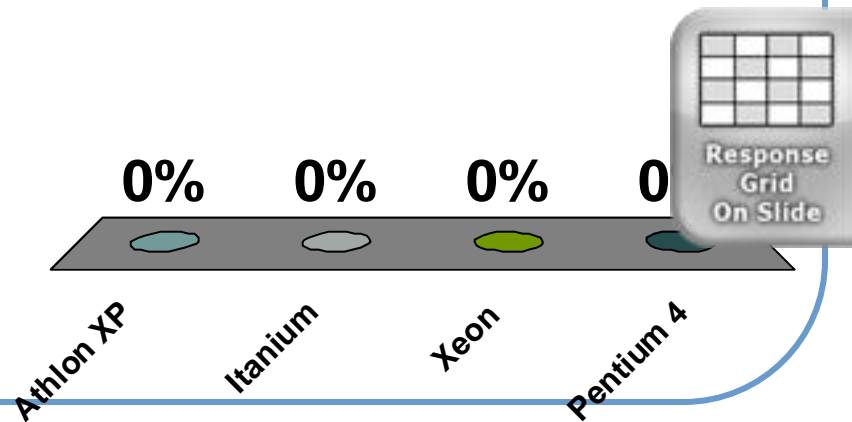

Which of the following would indicate a lack of thermal compound in a computer system?

1. A low RPM reading from the case fan
2. A high temperature reading from the hard drive
3. A rattling noise from the case fan
- ✓ 4. A high temperature reading from the CPU

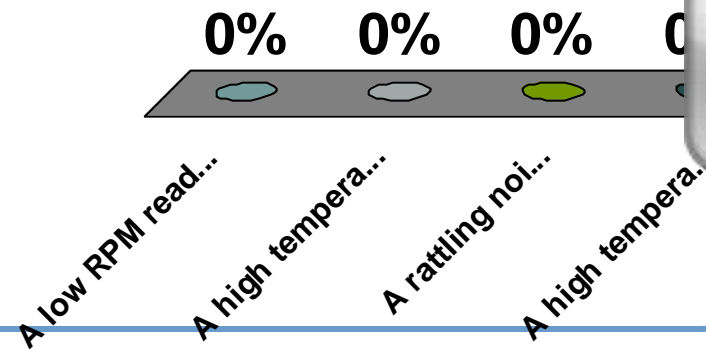

Which of the following is an example of active cooling?

1. Thermal compound
2. Shroud
- ✓ 3. Heatsink fan
4. Heat pipe

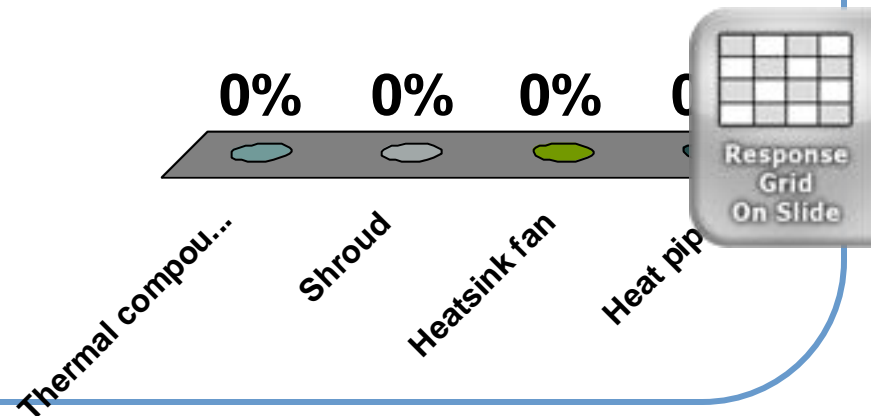

A technician has replaced the CPU in a workstation and now the user states that the computer powers off after ten minutes. Which of the following is the MOST likely cause?

1. The DVI cable is not connected.
2. The hard drive has become faulty.
3. The CMOS battery will not hold a charge.
- ✓ 4. The heat sink is not installed correctly

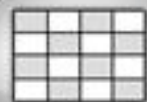
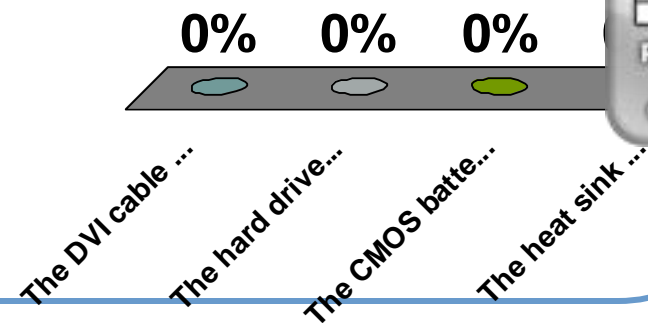

Response
Grid
On Slide

Which of the following will dissipate heat and requires no moving parts?

1. Liquid cooling system
2. Motherboard riser
3. Case fan
- ✓ 4. Heat sink

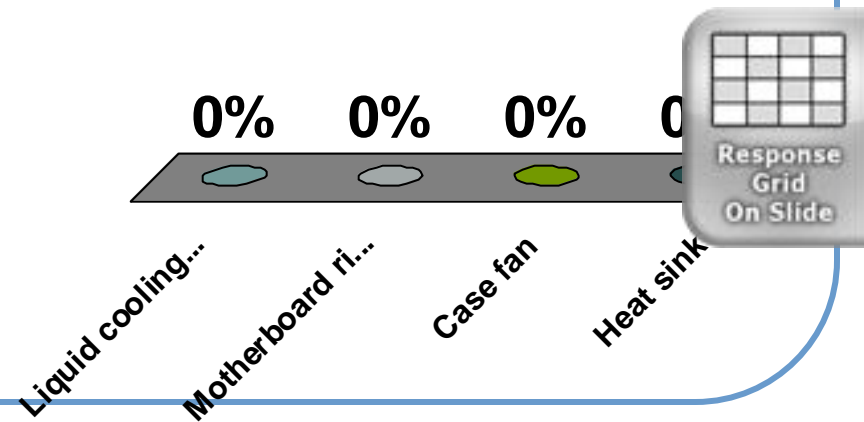

Which of the following processors are capable of running a 64-bit operating system? (Select THREE)

1. Turion
2. Xeon
3. Itanium
4. Pentium Pro
5. Sempron
6. Pentium M

- ✓ 1. 1, 2 & 3
2. 1, 2 & 4
3. 2, 3 & 4
4. 3, 4 & 5
5. 4, 5 & 6

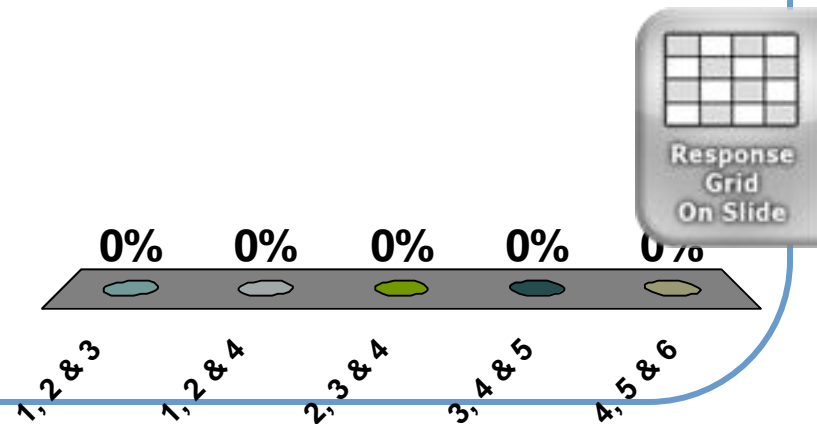

Which of the following BEST describes the purpose of a heat sink?

1. To provide a method to install a fan on a component
2. To provide a method to retain heat in a component
3. To store heat energy to be used at a later time
- ✓ 4. To remove heat from a component

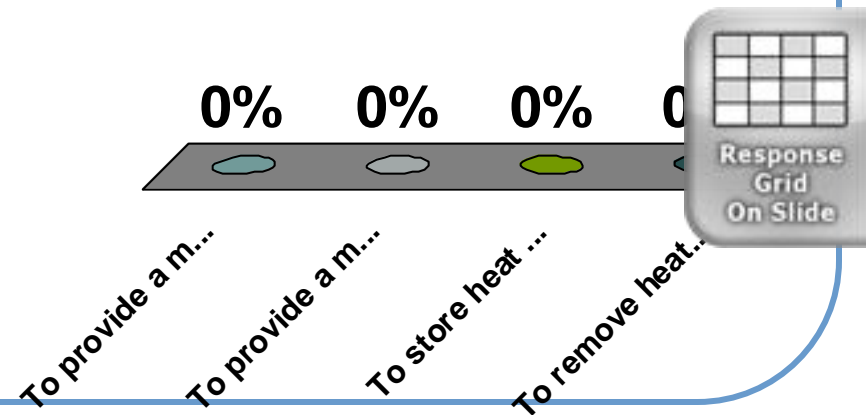

Which of the following describes a Quad Core processor?

1. A CPU with four direct channels to the FSB.
- ✓ 2. Four CPU cores operating off one CPU package.
3. A PC with four unique processors.
4. A CPU with four cache memory locations.

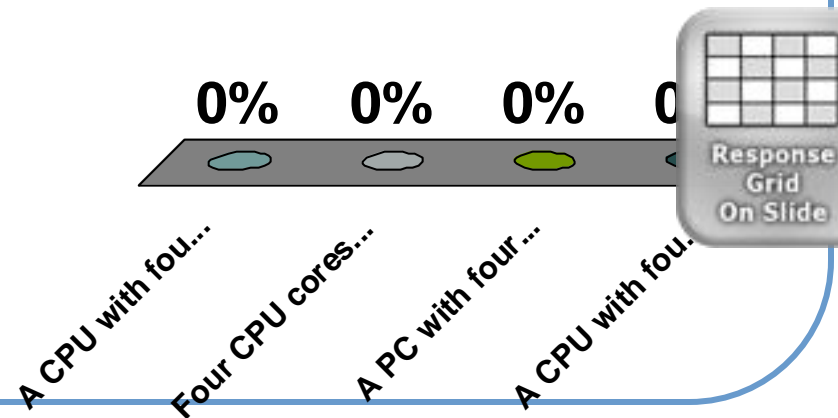

Which of the following is the MOST common way to cool a CPU?

1. Water cooling
- ✓ 2. Heat sink
3. Case fan
4. Air conditioning

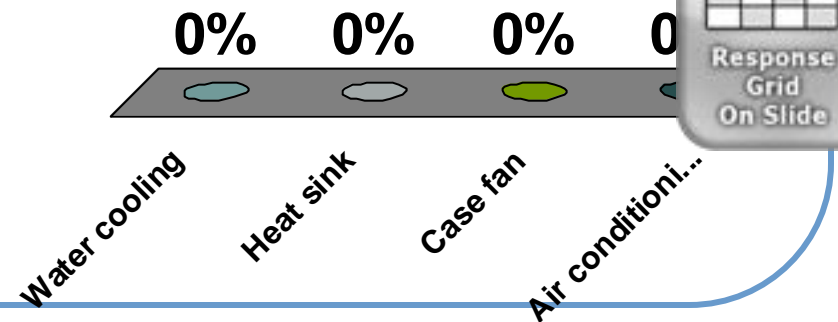

Which of the following is placed directly on the CPU in a new computer system to aid in the cooling process?

1. Heatsink
2. Fan
3. Liquid cooling system
- ✓ 4. Thermal compound

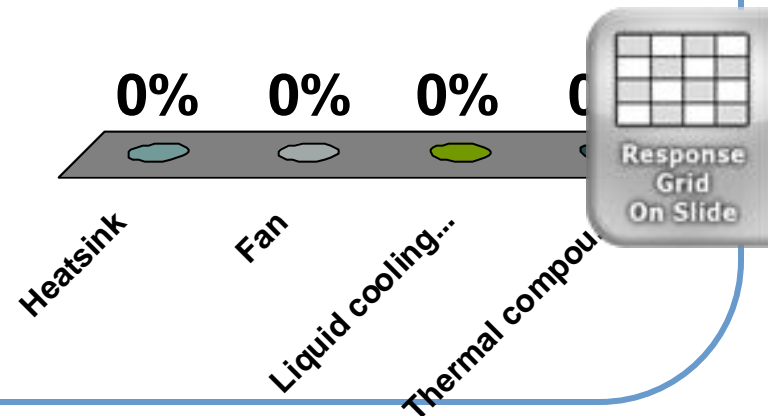

Thermal compound is designed to do which of the following?

1. Insulate a component from the friction of the heatsink
2. Reduce heat on a component through evaporation
- ✓ 3. Provide for heat transfer from a component to the heatsink
4. Quiet any vibration to a heatsink from a fan

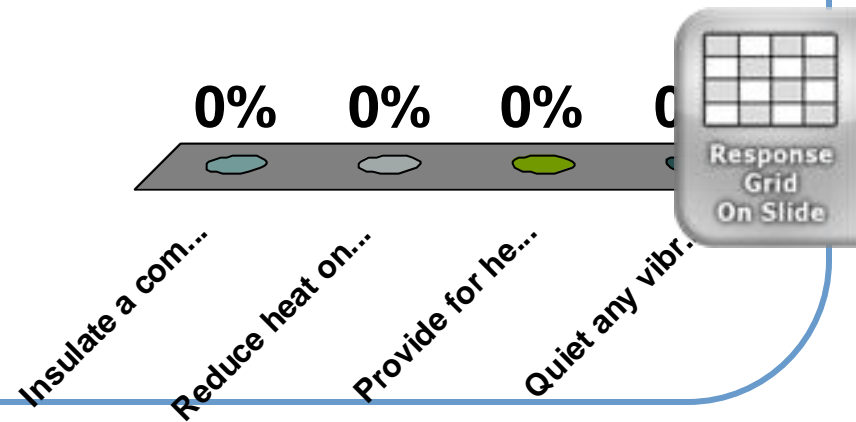

Which of the following describes the process of scheduling multiple processes simultaneously among multiple logical processors?

- ✓ 1. Hyper-threading
2. SpeedStep technology
3. Quad core processing
4. Dual core processing

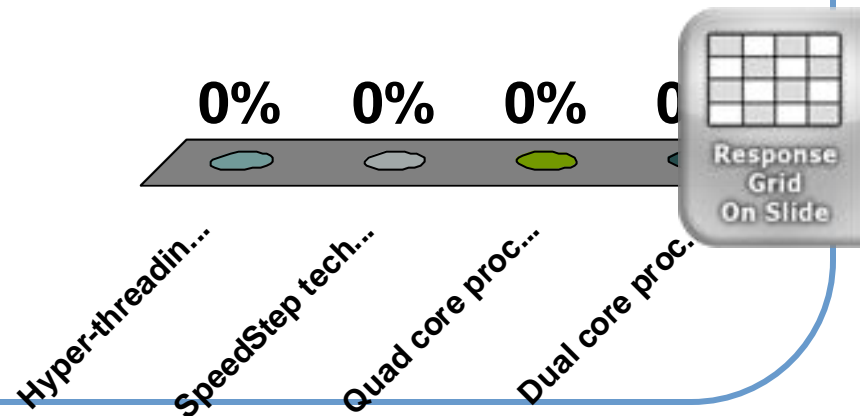

Which of the following is the reason why 64 is contained in the processor names, AMD Athlon 64 and 64 FX?

1. The processors contain 64K new transistors.
2. The processors have an additional 64 instruction sets.
- ✓ 3. The processors provide a 64-bit register.
4. The processors are made with a 64nm manufacturing process.

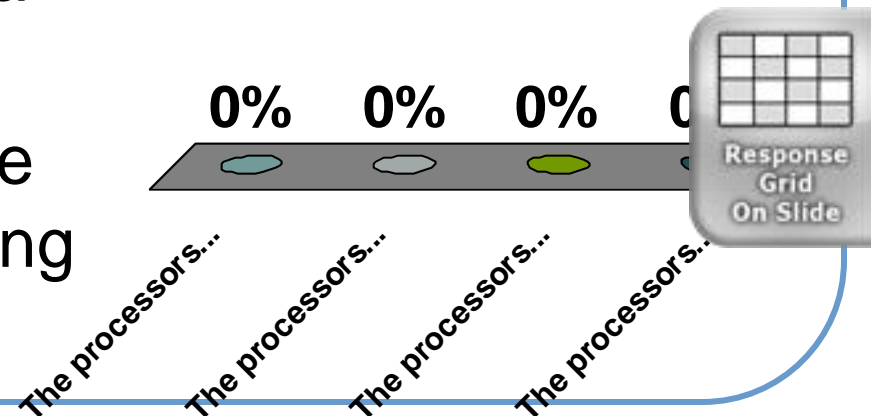

Which of the following processors uses a LGA775 socket?

1. Intel Itanium
- ✓ 2. Intel Core 2 Duo
3. AMD Athlon XP
4. AMD Athlon 64

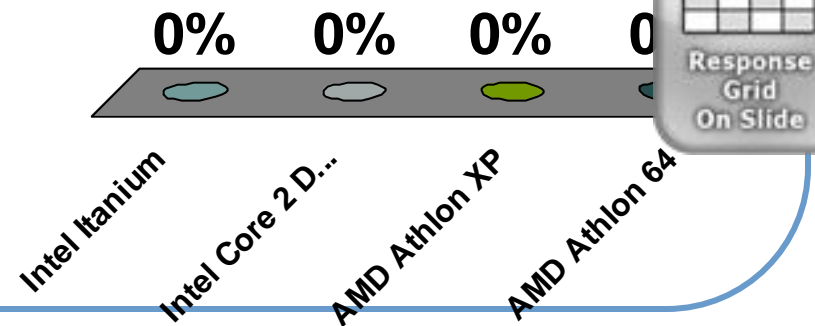

A dual core processor facilitates the processing of:

1. two-times the speed down one channel.
2. two bits down the same channel simultaneously.
3. two-times the speed down two separate channels.
- ✓ 4. two bits down two separate channels simultaneously.

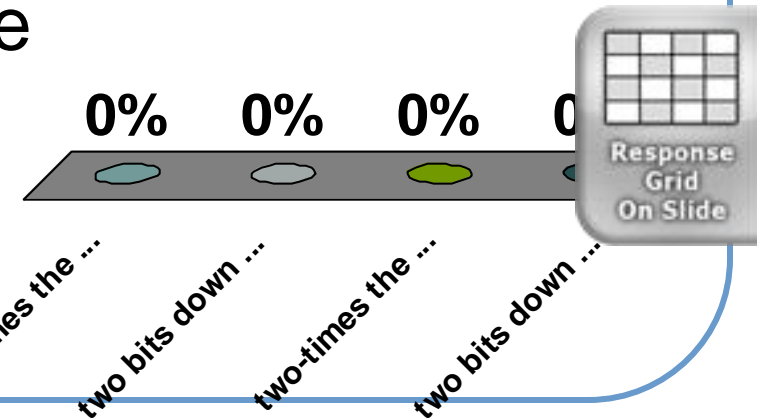

A computer's BIOS shows that the CPU temperature is above 80 degree Celsius. Which of the following steps should a technician take?

1. Remove CPU's heatsink, clean CPU's surface, and install the heatsink.
- ✓ 2. Clean CPU's surface and apply new layer of thermal grease.
3. Replace the CMOS chip.
4. Replace the case fan.

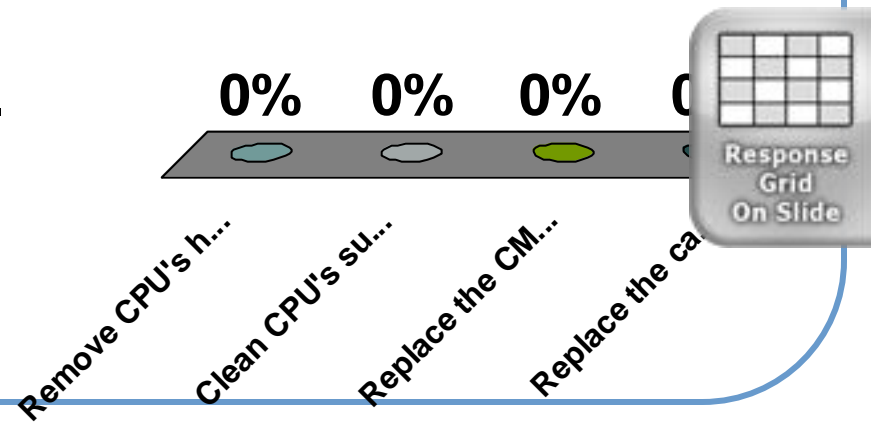

A technician receives a request to build a machine and install a 64-bit operating system.

Which of the following processors would the technician use in this system?

1. Pentium 4
2. Athlon XP
3. Celeron
- ✓ 4. Itanium 2

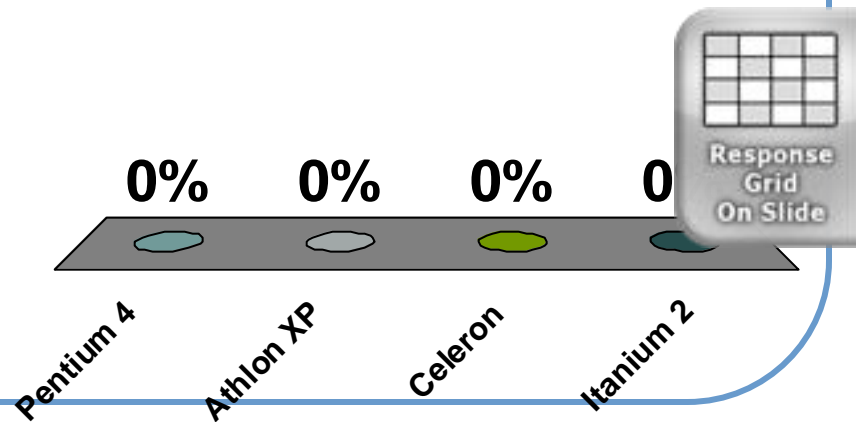

When installing the heatsink back into a computer after replacing a failed processor, which of the following must be done during installation?

- ✓ 1. Thermal compound must be installed between the processor and the heatsink.
2. An isopropyl alcohol pad must be placed between the processor and the heatsink.
3. An isopropyl alcohol pad must be placed between the processor and the system board.
4. Thermal compound must be installed between the processor and the system board.

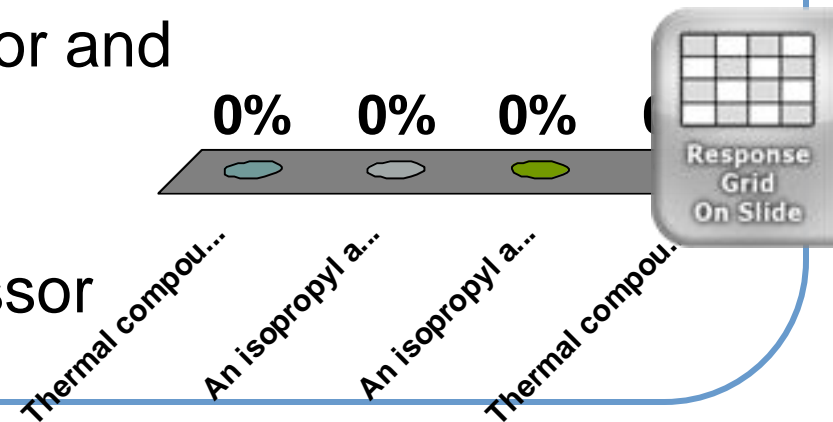

Which of the following processing types allows two instructions to be received and processed at the same time?

1. Quad core
2. Triple core
3. Dual core
- ✓ 4. Hyper-threading

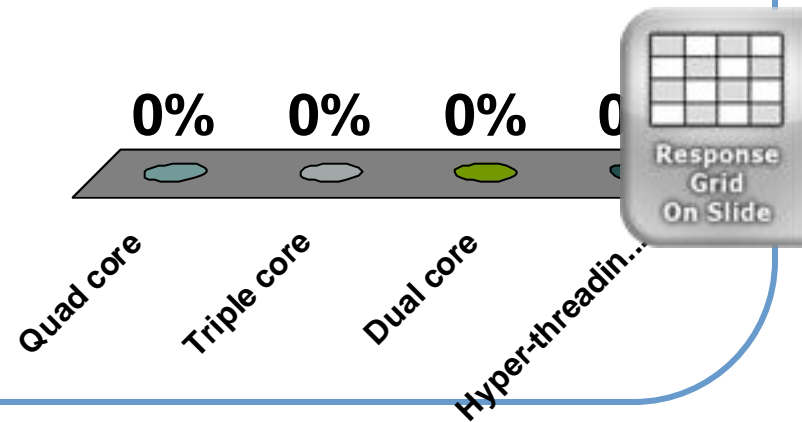

Which of the following provides the LEAST amount of power efficiency?

1. Quad core
- ✓ 2. Single core
3. Triple core
4. Dual core

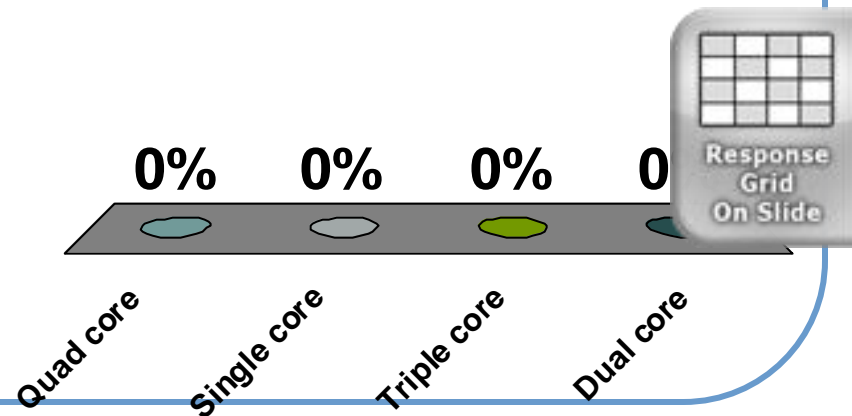

Which of the following processors would provide the BEST performance?

1. Pentium 4 with Hyper-Threading
2. Pentium Core 2 Duo
3. Single-Core Athlon64
- ✓ 4. 64-bit Core 2 Quad

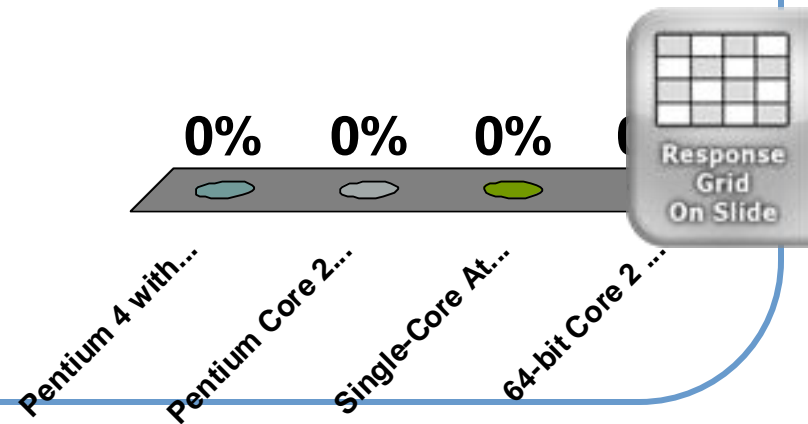

Which of the following is placed FIRST on top of the processor to aid in the cooling process?

1. Fan
2. Mounting bracket
- ✓ 3. Thermal compound
4. Heatsink

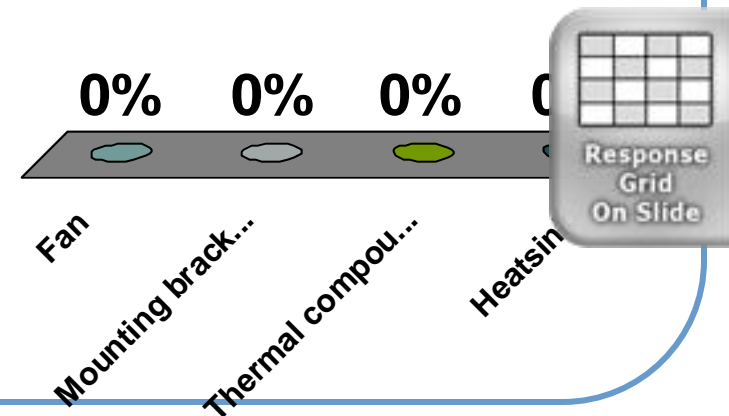

Which of the following would BEST provide cooling to a processor?

1. Case fan
2. Heatsink
- ✓ 3. Liquid cooling system
4. CPU fan

